

# SIPA - MachWall

---

February 2018

Presented by Bill Chaleff, John Fisher and Punit Chugh

**How many times have potential clients  
said to you:**

---

# How many times have potential clients said to you:

- “You mean your ‘Complete Package’ is just for the Exterior Walls ?!?”
-

# How many times have potential clients said to you:

- “You mean your ‘Complete Package’ is just for the Exterior Walls ?!?”
  - “What do you mean that SIPs are too expensive for the Interior Walls?”
-

# How many times have potential clients said to you:

- “You mean your ‘Complete Package’ is just for the Exterior Walls !?”
  - “What do you mean that SIPs are too expensive for the Interior Walls?”
  - “What do you mean that SIPs are too impractical for the Interior Walls?”
-

**Don't you wish you had better answers for them;**

**That you did have economical & practical interior panels to offer them ?**

**That you could offer a truly “Complete Package?”**

---

Introducing.....



The logo for MachWall, featuring a stylized icon of three right-pointing chevrons followed by the text "MachWall" in a sans-serif font.

**MachWall**







**MachWall offers features of regular SIPs that make sense for interior applications:**



## **MachWall offers features of regular SIPs that make sense for interior applications:**

- Studless construction – just upper track, lower track, and splines.



## **MachWall offers features of regular SIPs that make sense for interior applications:**

- Studless construction – just upper track, lower track, and splines.
- Both vertical and horizontal chases 6” on center for wiring and supply plumbing lines.



## MachWall offers features of regular SIPs that make sense for interior applications:

- Studless construction – just upper track, lower track, and splines.
- Both vertical and horizontal chases 6” on center for wiring and supply plumbing lines.
- Pre-cutting to meet the needs of the Project’s floorplan, which translates to cutting assembly times by 50%.....***or much more!***

**briefly;**

**The Primary Advantage of the SIPs you know --**

***Exchanging Site-built manufacturing  
and assembly for  
Factory built manufacturing  
and assembly.***

---

**In short;**

**This helps to move the Construction Industry closer to  
the toaster and the automobile...**

---

**In short;**

**This helps to move the Construction Industry closer to the toaster and the automobile...**

**...into the 21<sup>st</sup> century of factory made, mass-produced products where quality can exceed that of Artisan Construction, and production time and costs are collapsed.**

---

**We're headed there anyway...**

**...don't you think SIPA should help lead rather than follow?**

---



# Some MachWall product specifics:

- Core thicknesses to match standard light gage steel sizes from a minimum of 3 ½" to 6" or more.
- Skins may be almost anything, from gypsum wallboard to MgO with special coverings such as fabrics or wood veneers.
- Corners may be butted or mitered.
- Heights governed by your choice of skins.

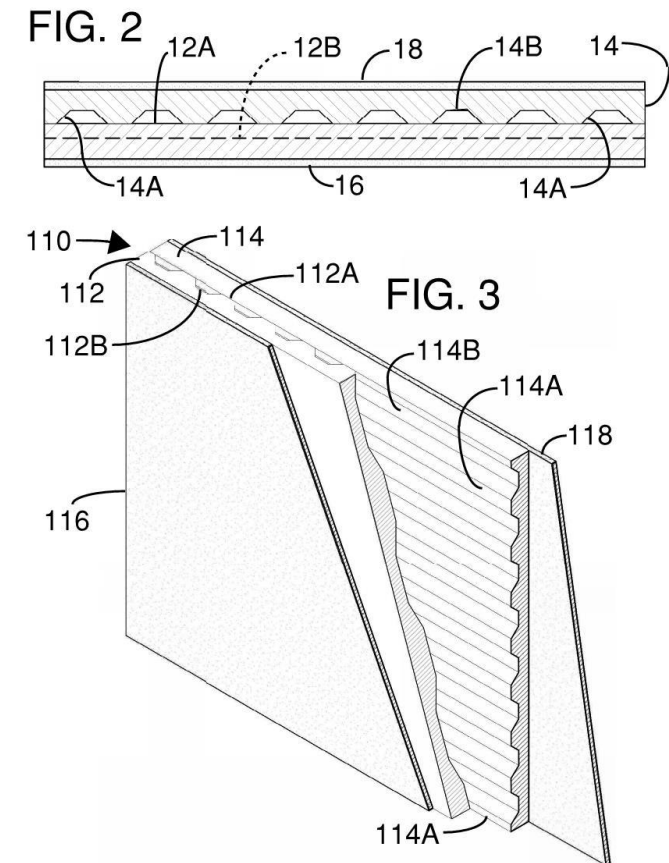

We sincerely hope that SIPA members will try

adding  products to what they offer their clients in terms of packages and services,

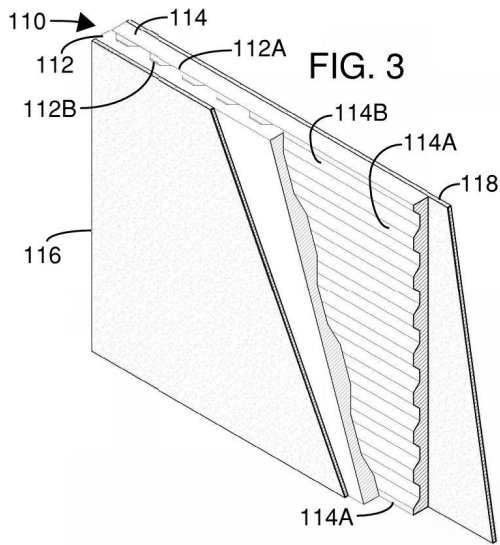
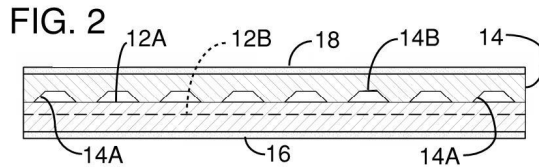

but more importantly, that they seriously think about moving from the Custom Home Market to the commercial sector and break through the 2% glass ceiling that we have struggled against for so many years.

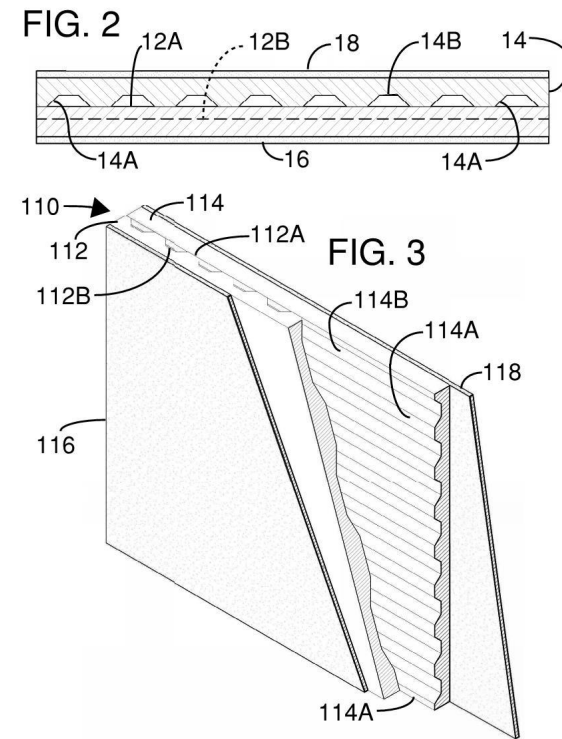

**Thank you.**





**Presenters and MachWall Co-inventors:**

Punit Chugh

John Fisher

Bill Chaleff

Architect, AIA, LEED AP

[Chaleff & Rogers Architects](#)

MachWall™

2272 Montauk Highway

New York, Bridgehampton 11932

631-204-5590 (T)

[info@machwall.com](mailto:info@machwall.com) (E)

[www.machwall.com](http://www.machwall.com)

---